

Laser Diode/TEC Controllers—Compact



up to 1A laser current, , constant current/power mode, up to 2A TEC current, ultra-stable feedback control

DATASHEET [Return to the Webpage](#)



Features

- Compact
- Easy to User
- LD Current up to 1A
- Compatible with All Laser Types
- Adjustable Laser Diode Current
- Constant Current or Constant Power
- Ultra-Stable Feedback Control

Applications

- Laser Modules
- Laboratory Use
- Systems



Laser Safety

This product meets the appropriate standard in Title 21 of the Code of Federal Regulations (CFR). FDA/CDRH Class 1M laser product. This device has been classified with the FDA/CDRH under accession number 0220191. All versions of this laser are Class 1M laser products, tested according to IEC 60825-1:2007 / EN 60825-1:2007. An additional warning for Class 1M laser products. For diverging beams, this warning shall state that viewing the laser output with certain optical instruments (for example eye loupes, magnifiers, and microscopes) within a distance of 100 mm may pose an eye hazard. For collimated beams, this warning shall state that viewing the laser output with certain instruments designed for use at a distance (for example telescopes and binoculars) may pose an eye hazard.

Wavelength = 1.3/1.5 μm. Maximum power = 30 mW.

Rev 11/22/24

This LDCD series of Compact Laser Diode Driver and TEC Temperature Controller is based on a proven design that have wide deployments. The module provides a low noise laser driving current up to 1A, and TEC colling current up to 2A. It is designed for easy integration into your laser system: 1) connect the LDCD to a DC power supply using the accompanied cable with a connector, 2) select a mounting hardware for your type of laser and connect to the LDCD with the prefabricated latching connector. The setups are detailed in the following pages. The laser controller setting adjustments are straightforward with turning pots, once the limits have been set to protect the laser.

Specifications

Parameter	Min	Typical	Max	Unit
Output Laser Control Current			1	A
Noise Ripple		150	180	μA RMS
Stability ^[1]	1hr	0.08		%
	24hr	0.04		%
Slow Start Ramp		15		mA/ msec
External Modulation Bandwidth ^[1]	DC		500	kHz
External Modulation Depth ^[2]		97		%
External Modulation Rise/Fall ^[3]		300	-	ns
Power Supply Voltage	4.5	5	6	V
Power Supply Current			6	A
Internal Power Dissipation ^[4]			2	W
Operating Temperature	-40		80	°C
Storage Temperature	-60		85	°C
TEC Control Current			2.2	A
Lase Temperature Stability ^[4]	0.02		0.3	°C

Notes:

- [1] Constant current
- [2] 100kHz since wave
- [3] laser current 500 mA
- [4] 25°C

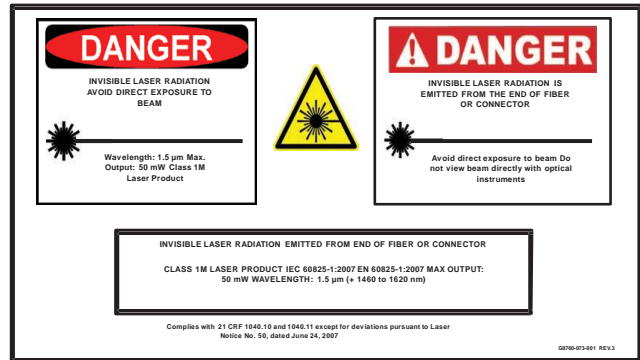

Laser Diode/TEC Controllers—Compact



up to 1A laser current, , constant current/power mode, up to 2A TEC current, ultra-stable feedback control

DATASHEET

Connection Guide

- V+ controller power supply
- Vld laser power supply, if <5V connect to V+
- Vtec TEC power supply, if <5V connect to V+
- CM1 laser setting selection: external or internal
- In external laser setting input (0-2V) 0-100%, if CM1 is set as external
- CM2 laser control mode selection: constant power(CP), or constant current(CC)
- Tlimit external TEC current setting
- LDA laser diode anode
- LDC laser diode cathode
- PDA power detector anode
- IM laser current monitor
- PM laser power monitor
- T+ TEC positive connection (R~1 Ω, >10W)
- T- TEC negative connection (R~1 Ω, >10W)
- S+ thermistor positive connection (R~10k Ω, >0.25W)
- S- thermistor negative connection (R~10k Ω, >0.25W)

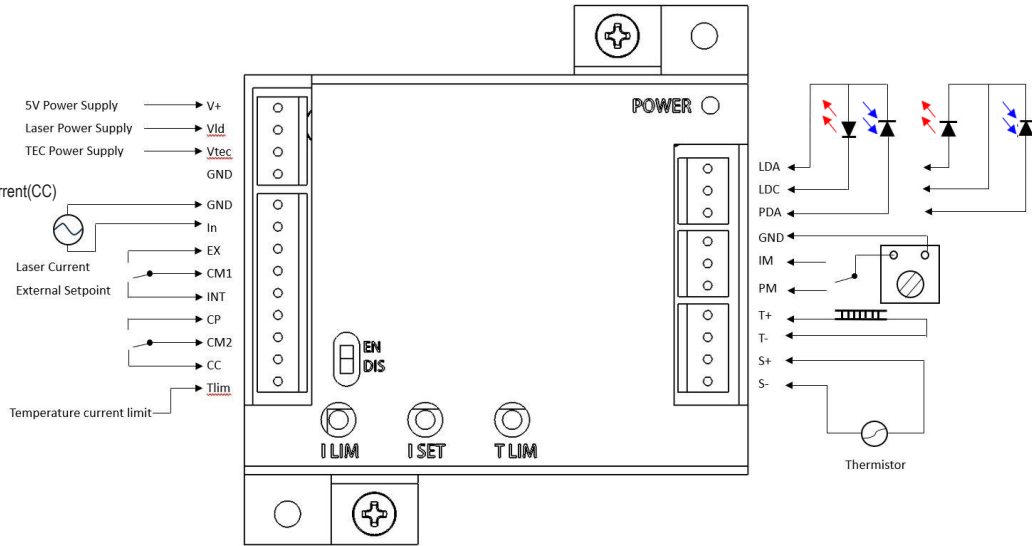

Note: only suitable to driver lasers with connection type of A and B of both butterfly and TOCAN packages

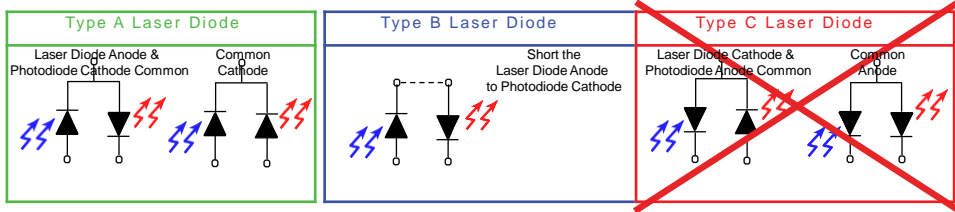

Laser Mounts

Note: we offer laser mounts for butterfly, DIL, and TOCAN packages with cable direct connect to the LCD laser driver module

- | | | |
|---|---|--|
| <ul style="list-style-type: none"> ■ Butterfly ■ Cable included ■ Bottom to heat sink ■ \$285 | <ul style="list-style-type: none"> ■ TOCAN ■ Cable included ■ Bottom to heat sink ■ \$145 | <ul style="list-style-type: none"> ■ 14-pin DIL ■ Cable included ■ Bottom to heat sink ■ \$235 |
|---|---|--|

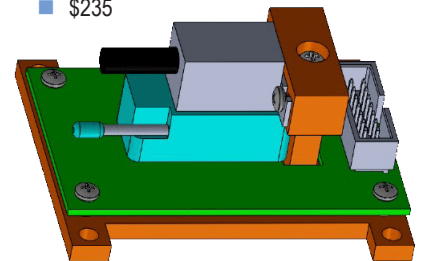
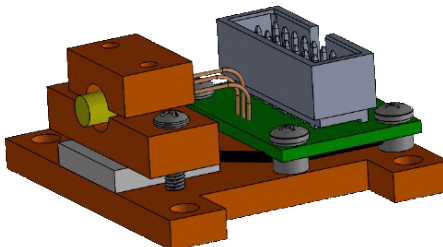
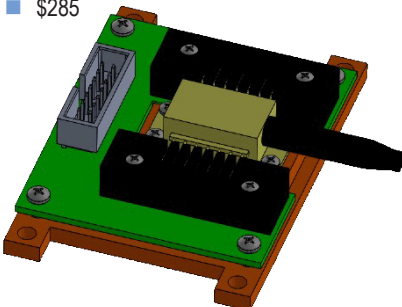

Laser Diode/TEC Controllers—Compact



up to 1A laser current, , constant current/power mode, up to 2A TEC current, ultra-stable feedback control

DATASHEET

Mechanical Dimensions (mm)

Laser Control Kit

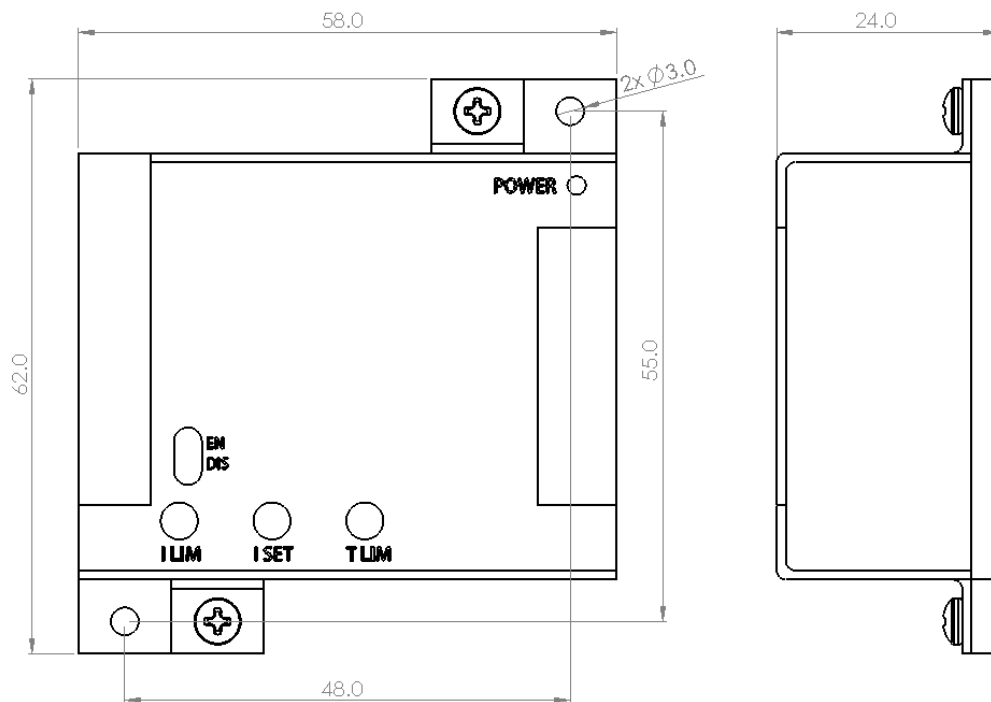

TO Can Laser Mounting

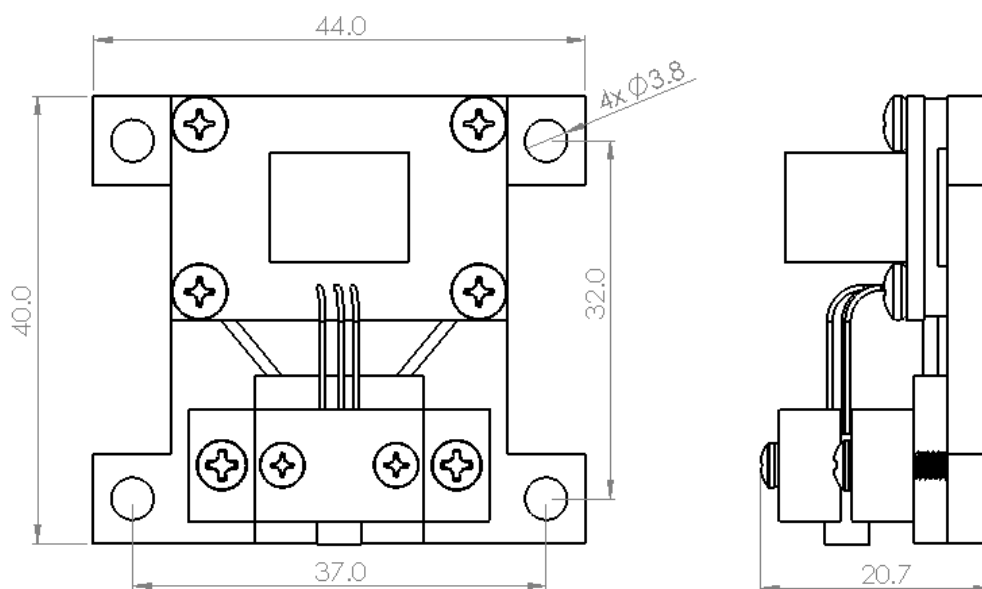

*Product dimensions may change without notice. This is sometimes required for non-standard specifications.

Laser Diode/TEC Controllers—Compact



up to 1A laser current, , constant current/power mode, up to 2A TEC current, ultra-stable feedback control

DATASHEET

Butterfly LD A&B Pin Map

PIN	Connection
1	Thermistor
2	Thermistor
3	LD Cathode (-)
4	PD Anode (+)
5	PD Cathode (-)
6	TE Cooler (+)
7	TE Cooler (-)
13	LD Anode (+)

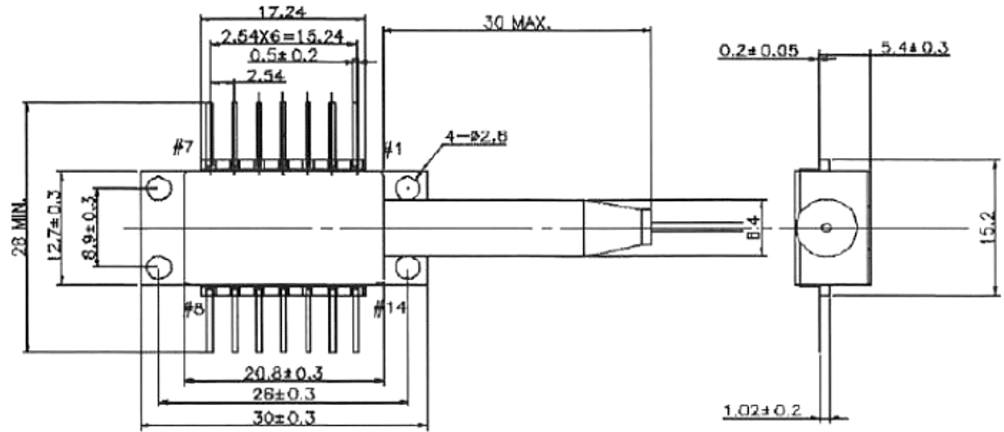

PIN	Connection
1	TE Cooler (+)
2	Thermistor
3	PD Anode (+)
4	PD Cathode (-)
5	Thermistor
10	LD Anode (+)
11	LD Cathode (-)
14	TE Cooler (-)

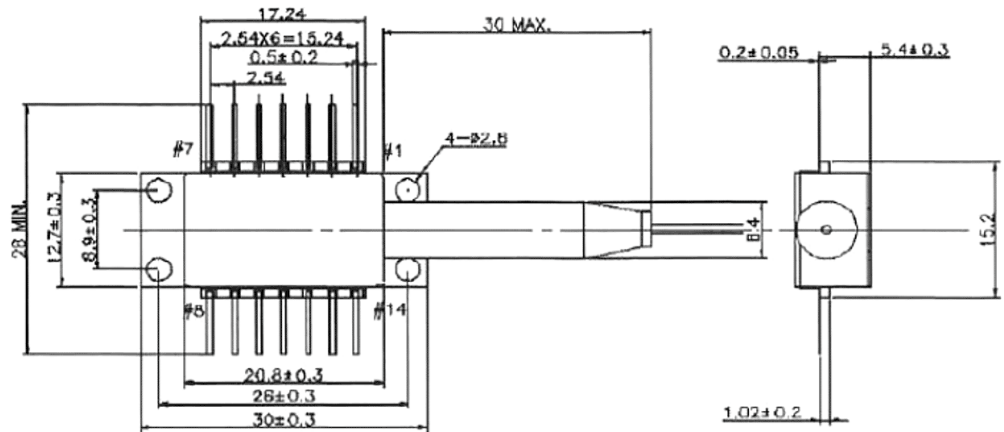

TOP VIEW

*Product dimensions may change without notice. This is sometimes required for non-standard specifications.

Laser Diode/TEC Controllers—Compact



up to 1A laser current, , constant current/power mode, up to 2A TEC current, ultra-stable feedback control

DATASHEET

Manual Setting

- EN/DIS Enable or Disable Laser Control
- LLIM Hard Setting the Maximum Laser Current Limit
- ISET Set the Laser Current for Internal Control Mode (CM1 is set Internal)
- TLIM Hard Setting the Maximum TEC Current

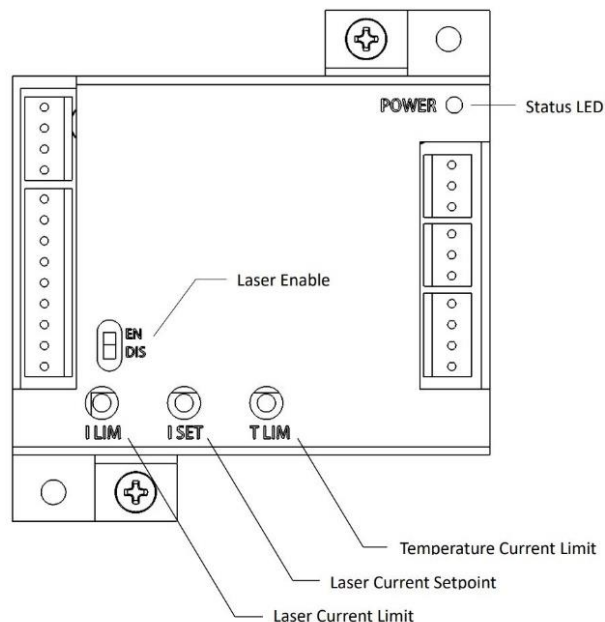

Ordering Information

Prefix	Configuration	Laser Current	TEC Current	Type	Package	Power Supply	Laser Mount
LDCK-	Standard = 1 Special = 0	1A = 1 Special = 0	2.2A = 1 Special = 0	Standard = 11 Special = 00	Module = 1 Benchtop = 2 Special = 0	Non = 00 Yes = 11	None = 0 TOCAN A = 1 Butterfly A = 2 Butterfly B = 3 Butterfly C = 4 TOCAN B = 5 DIL A = 6 DIL B = 7

Red is non-standard specially made at a higher cost

Caution Extremely Electrostatic Sensitivity



- Never touch laser diode and the module using hands
- Always use protections when handle a laser diode
- Recommend mounting the laser diode using an ionic gun and ESD finger cots



Laser Diode/TEC Controllers—Compact



up to 1A laser current, , constant current/power mode, up to 2A TEC current, ultra-stable feedback control

DATASHEET

Typical Laser Output Stability (butterfly package with temperature control)

